



Super Efficient

Compressed Air
Maintenance Free
Solutions

Discover the transformative impact
Zenflow Aircon can have on your
manufacturing and industrial
processes.



Elevating Industrial Performance

Sturdy | Reliable | Efficient | Saves Time & Money





ZENFLOW
— AIRCON —

Enhanced Quality Check and Product Testing





Focus on Precision

Our team of highly skilled engineers has been meticulously crafting products that embody unparalleled quality and innovation.





What We Do

We specialize in designing and manufacturing advanced compressed air-operated solutions that enhance productivity, optimize energy usage, and support sustainable industrial practices.



Our product portfolio addresses a wide spectrum of industrial applications—from cooling electrical panels and machining processes to material conveying, cleaning, and air flow management. Engineered for performance and efficiency, our solutions operate without electricity, require zero maintenance, and eliminate operational mess, making them both cost-effective and environmentally responsible.

With a strong focus on innovation and application engineering, we work closely with our clients to solve complex industrial challenges and deliver tailored, high-impact solutions.



ZENFLOW
—AIRCON—

Who We Are

Zenflow Aircon is a distinguished, family-owned enterprise with over three decades of expertise in vortex tube and air amplification technologies. Since our inception in 1996, we have been driven by a singular vision—to engineer high-performance compressed air solutions that redefine industrial efficiency.

Our team of highly skilled engineers combines deep technical knowledge with precision craftsmanship to deliver products that meet the highest standards of quality, reliability, and innovation. By operating with a direct-to-customer approach, we eliminate intermediaries—ensuring greater value, transparency, and trust in every engagement.

At Zenflow Aircon, we are not just manufacturers; we are problem-solvers, committed to building long-term partnerships through technical excellence, responsive service, and uncompromising integrity.





ZENFLOW
—AIRCON—



VISION

To emerge as a globally recognized leader in compressed air technology by continuously expanding our product capabilities, advancing innovation, and building enduring client partnerships across industries worldwide.

Our Vision



MISSION

To revolutionize industrial efficiency on a global scale by delivering innovative, reliable, and high-performance compressed air solutions. We are committed to setting new benchmarks in engineering excellence while enabling businesses to achieve greater productivity, sustainability, and operational precision.

Our Mission



Our Products



Active Air Amplifier

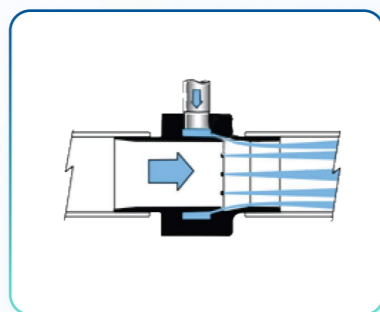

Active Air Conveyor



Air Blade / Air Curtain



Air Nozzles & Jets



Blind Hole Cleaner



Barrel Pump



Cold Air Gun

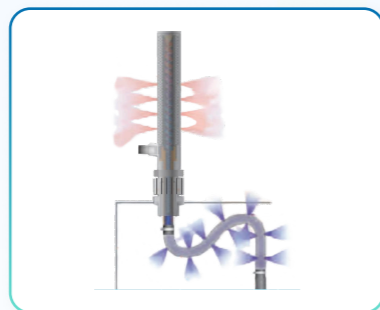

Cabinet Cooler/
Panel cooler



Coolant filter/ Chip
Collector



360° Degree Air
Wipes



Micron line filter



Safety Blow Guns



ZENFLOW
— AIRCON —

Industries We Serve



MEDICAL



PNEUMATIC



PHARMA



OIL & GAS



STEEL

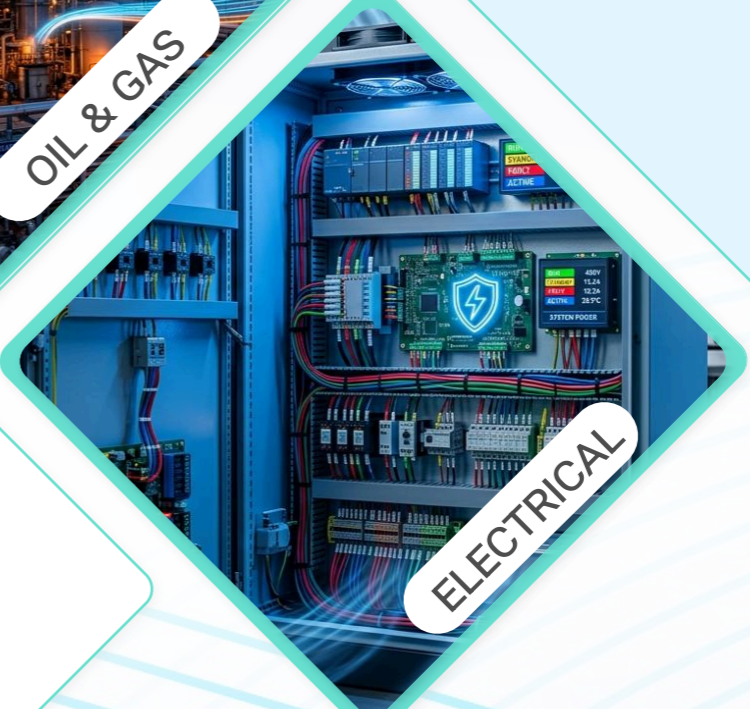

ELECTRICAL



Contact us Now

Call us



+91 8779423415



+1 (825) 785-1641

Email

sales@zenflowaircon.com

Website

www.zenflowaircon.com

